



CCC1380UH Series Digital CCD Color Camera

1/3-INCH, ULTRA HIGH RESOLUTION, 540 TVL (NTSC/PAL), COMPACT

Product Features

- Compact Body Style
- 1/3-Inch Format CCD Imager
- Digital Signal Processing
- 540 TV Lines
- 0.7 Lux Sensitivity
- CS Lens Mount (C-Mount Lenses Require Optional Adapter)
- Autosensing DC/Video Drive Auto Iris
- On-Screen Menu Configuration
- Automatic/Manual White Balance Settings for Difficult Lighting Situations
- Selectable Automatic Gain Control (AGC), Electronic Shutter Control (ESC), and Backlight Compensation (BLC)
- Flickerless Mode
- Analog Eclipser Function
- Autosensing Power (24 VAC/12 VDC with Line Lock or Internal Synchronization)
- Internal Top/Bottom Mount



(LENS NOT SUPPLIED WITH CAMERA)

The **CCC1380UH** is one of Pelco's smallest full-featured digital color CCD cameras. It is designed to provide superior picture quality over a wide range of conditions. The camera's compact size, combined with its numerous features, makes it the ideal camera for most applications.

The **CCC1380UH** is an ultra high resolution digital camera with 540 TVL of resolution and 0.7 lux sensitivity. Camera features include auto-sensing power (24 VAC with internal line lock or 12 VDC with internal synchronization), automatic gain control (AGC), electronic shutter control (ESC), and flickerless mode. The **CCC1380UH** also includes AWB white balance for difficult lighting situations, an analog eclipser function that allows the auto iris lens to create clear images in a dark area with a strongly backlit background, and backlight compensation that adjusts the picture to prevent objects from appearing dark due to a strong backlight. These fine tuning features are easily set using the on-screen menus.

The **CCC1380UH** has a standard CS lens mount and can be used with fixed, manual, or auto iris (DC or video drive) lenses. The iris is controlled through a standard four-pin square connector that is included on all Pelco auto iris lenses.

The **CCC1380UH** is quick and easy to install. It is ideal for use with DF5, DF8A, EH100, EH3508, and EH2508 enclosures. The camera is also featured in Pelco's DomePak® and ImagePak® fixed camera dome/enclosure packages.



TECHNICAL SPECIFICATIONS

MODELS

CCC1380UH-6	1/3-inch ultra high resolution digital color CCD camera, 24 VAC or 12 VDC, NTSC format
CCC1380UH-6X	Same as CCC1380UH-6 except PAL format

GENERAL

Imaging Device	1/3-inch interline transfer CCD
Picture Elements	
NTSC	768 (H) x 494 (V) (approx. 380K)
PAL	752 (H) x 582 (V) (approx. 440K)
Sensing Area	3/16 x 1/8-inch (4.7 x 3.5 mm)
Scanning System	
NTSC	525 lines, 2:1 interlace
PAL	625 lines, 2:1 interlace
Synchronization System	AC line lock/internal
Horizontal Resolution	540 TV lines
Auto Iris Lens Type	DC/video drive (autosensing)
Minimum Illumination	0.7 lux, F1.2, 40 IRE, AGC on, 75% reflectance
Signal-to-Noise Ratio	>48 dB
Vertical Phase	Adjustable $\pm 90^\circ$
Automatic Gain Control	Selectable: on/off
Electronic Shutter Control	Selectable: on/off
Backlight Compensation	Selectable: on/off
Eclipser Function	Selectable: on/off
Auto White Balance	Selectable: on/off, 2 modes
Internal Synchronization	Selectable: on/off
Gamma	Selectable: 0.6/1.0
Flickerless Mode	Selectable: on/off
Signal Processing	Digital signal processing (DSP)
Video Output	1 Vp-p, 75 ohms
Auto White Balance Range	2,500° to 9,500°K

ELECTRICAL

Power Requirements	
CCC1380UH-6	24 VAC $\pm 15\%$ /12 VDC $\pm 15\%$, 60 Hz
CCC1380UH-6X	24 VAC $\pm 15\%$ /12 VDC $\pm 15\%$, 50 Hz
Power Consumption	3 watts
Power Connector	2-pin terminal block with screw lock
Video Connector	BNC
Auto Iris Connector	4-pin connector (miniature square)
Controls	5-position button

MECHANICAL

Lens Mount	CS mount
Camera Mount	1/4-inch UNC-20 screw, top or bottom of camera housing

ENVIRONMENTAL

Operating Temperature	14° to 122°F (-10° to 50°C)
Storage Temperature	-40° to 140°F (-20° to 60°C)
Operating Humidity	20% to 80%, noncondensing
Storage Humidity	20% to 90%, noncondensing

PHYSICAL

Weight (without lens)	0.44 lb (0.20 kg)
Shipping Weight	1 lb (0.45 kg)

CERTIFICATIONS

- CE, Class B
- UL Listed
- UL Listed to Canadian safety standards
- FCC, Class B

RECOMMENDED MOUNTS

BS1750/CM1750/ CM1750S/TB1750	Adjustable swivel head camera mounts for wall, ceiling or pedestal mounting.
----------------------------------	--

RECOMMENDED POWER SUPPLIES

TF2000	Power supply for one 24 VAC camera, 20 VA
MCS Series	Multiple 24 VAC camera power supply, indoor
WCS Series	Single/multiple 24 VAC camera power supply, outdoor

RECOMMENDED LENSES

13FA, FD Series	Fixed focal length lenses, 1/3-inch format. FA (manual iris); FD (auto iris, DD).
13VA, VD Series	Varifocal lenses, 1/3-inch format. VA (manual iris); VD (auto iris, DD).
13ZD Series	Motorized zoom lenses, 1/3-inch format (auto iris, DD).

LENS ACCESSORIES

LDC100	Auto iris drive converter. Converts a DC-drive auto iris lens to a video drive auto iris lens. Compatible with all lens size formats.
PCMA40	Lens adapter. Adapts standard C-mount lenses to CS-mount cameras.

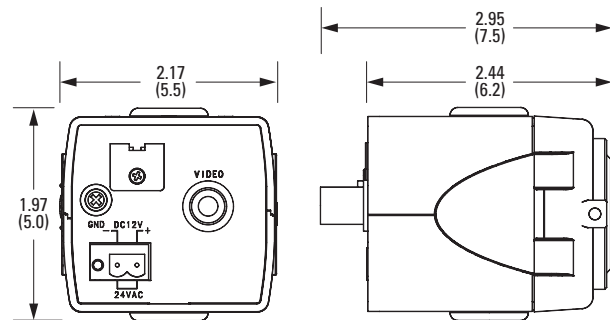

NOTE: VALUES IN PARENTHESES ARE CENTIMETERS; ALL OTHERS ARE INCHES.

NOTE: For outdoor camera installations, a Pelco enclosure is recommended.



Pelco Worldwide Headquarters:
3500 Pelco Way, Clovis, California 93612-5699 USA
USA & Canada Tel: (800) 289-9100 • FAX (800) 289-9150
International Tel: (559) 292-1981 • FAX (559) 348-1120
www.pelco.com

Pelco, the Pelco logo, DomePak, and ImagePak are registered trademarks of Pelco. Specifications subject to change without notice. ©Copyright 2007, Pelco. All rights reserved.